

# Hexaflexagon Template and Instructions

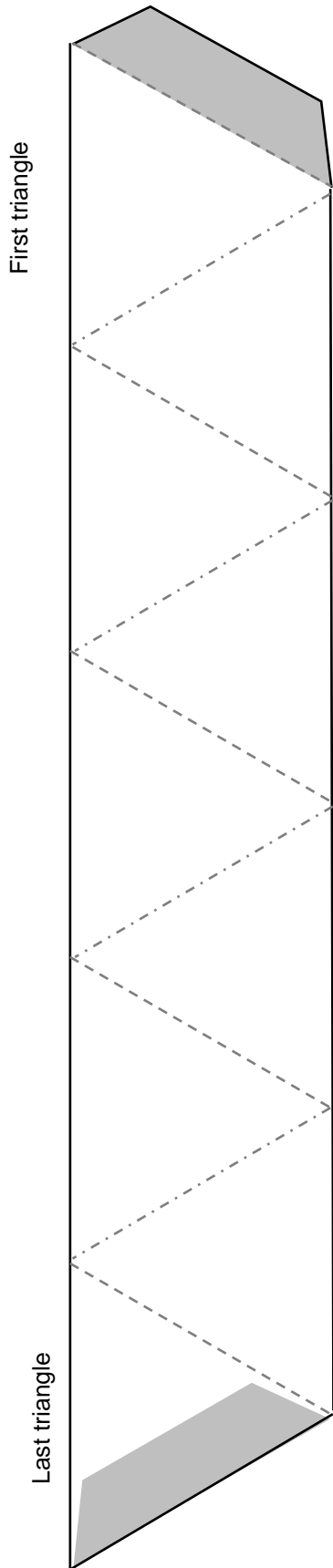

1. Cut out along solid lines.
2. Fold along mountain and valley folds according to origami notation at the bottom of the page.
3. Unfold, and fold again as below. Reverse side of paper is shown in polka dots. As you fold, make sure the edge of the paper lines up with the dotted lines.

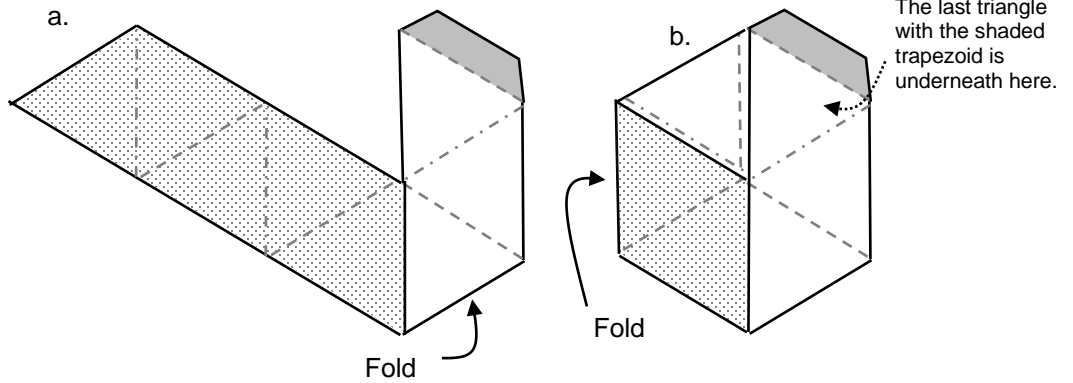

- c. Lift up the last triangle from underneath and place it on top of the first triangle.

